



Read all instructions prior to installing product.
Refer to manufacturers safety instructions when operating any tools.

ROOF TOP DECK WITH SLEEPER SYSTEM

Installation Instructions

To register your product, please visit: barretteoutdoorliving.com

To obtain and review a copy of the warranty please visit barretteoutdoorliving.com.
You may also contact us at 1-877-265-2220 or email Cs.outdoorliving@ebarrette.com

Deck must be designed to ensure that proper drainage and air flow are maintained.

- Maintain a gap where decking meets a solid wall. Recommended gap is 3/8" (9.5mm). Minimum gap is 1/4" (6.4mm), maximum gap is 1/2" (12.7mm).
- Maintain 3/16" (4.8mm) gap between boards (this is the standard gapping for DuraLife products).
- Air should be allowed free movement under the structure, do not cover or enclose the open end of the deck.
- Sleepers must be large enough to maintain 2" (51 mm) spacing under the decking.
- Sleeper arrangement shall not block / impede drainage flow.

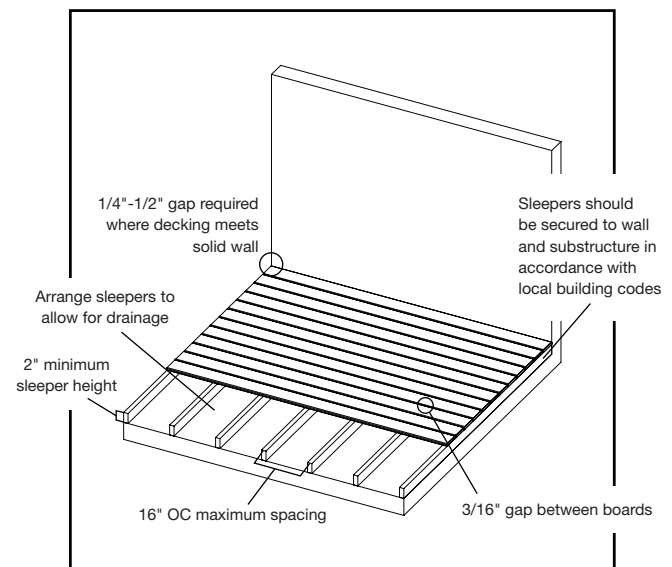

Construction

- Sleepers must be 16" (406 mm) OC maximum spacing.
 - It is recommended a 1/4" (6.4mm) plastic spacer be used between sleepers and subsurface to aid drainage and promote drying.
- Sleepers must be made from rot resistant materials.
- Please refer to decking installation instructions for guidance when attaching DuraLife deck boards to support structure.

The above is a simple guideline to reduce the issues that accompany all roof top deck installations. Following these guidelines and following current International Building Codes will help minimize rooftop installation issues. Please contact DuraLife Decking with any questions regarding your specific decking project.